

AP MODULE FOR PNEUMATIC CRIMP TOOLS

SEE PAGE 5 FOR IMPORTANT INFORMATION CONCERNING LIMITED WARRANTY, AND LIMITATION OF LIABILITY

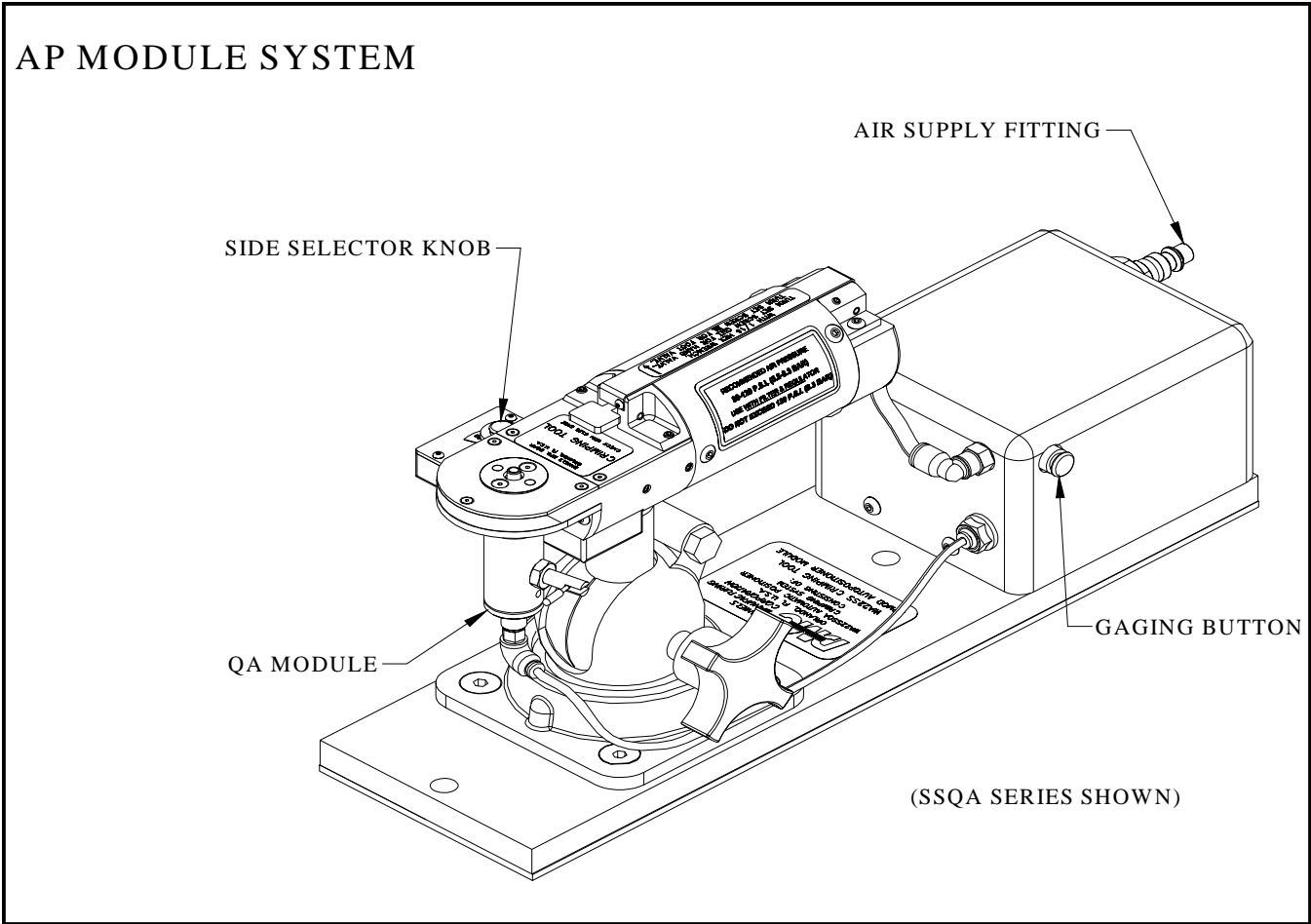

The SS (Side Selector) & standard Series of pneumatic crimp tools are available for the semiautomatic crimping of contact/wire assemblies. A special module is mounted to an extended base plate with a bench mount and either a WA22, WA22P, WA27F or SS version pneumatic crimp tool. Separate locator modules are attached or removed without use of tools. Users place contact/wire assemblies into the extended positioner insert and push downward until it bottoms and crimps.

The system operates from standard shop air 80-120 psi (5.5-8.27 BAR). Modules are available for most contacts for existing "K" and "86" Positioners and "TH" and "TP" heads sizes 12 thru 26. These modules may be ordered separately.

AP MODULE FOR PNEUMATIC CRIMP TOOLS

GENERAL

This family of tools provide improved production efficiencies for crimping contact/wire assemblies. Additionally, a bayonet attachment system provides quick interchange of locator/positioner modules for different crimping requirements while the side selector positioning provides easy, visible access for crimp depth selection. Go/No-Go gaging is easily performed.

OPERATION

Tools ordered with a locator will come fully assembled and ready for your crimping need. Just plug your shop air supply into the fitting provided on the base plate module. Adjust the selector knob as specified on the dataplate of the QA module for the size wire you are crimping. Place an uncrimped contact with wire into the positioner insert and push down on the assembly in one continuous motion until it bottoms to activate the crimp tool (fig 1).

CAUTION: Smaller wire sizes (24-28) are not very rigid and some difficulty may be experienced when pushing down on the contact/wire assembly. AP systems are not recommended for wire sizes smaller than 26 AWG.

Check the location of the crimp on the wire barrel of the contact. The crimp should be between the inspection hole and the top of the barrel (fig. 2). The top of the contact should not be squared and the inspection hole should be intact.

Tools ordered without locators will additionally require the installation of a quick assembly (QA) positioner module. These modules are constructed with bayonet type mounting protrusions enabling easy removal and assembly. All modules are clearly marked for contact type and wire size selector setting.

Install the QA module by guiding the lead diameter into the positioner guide on the underside of the tool crimp area. (Disconnect the system from the shop air source.) Rotate while lifting module until the bayonets align with slots in the guide (plunger should be to the left front). Pull module upward with sufficient force for bayonet pins to clear guide and rotate counterclockwise (from tool top) 90° until bayonet pins lock. Check that positioner insert moves freely up and down, (tang of plunger in the shallow slot). Push end of the air bleed hose into the right angle fitting until it can go no further. Connect the system to a shop air source. (fig. 3).

Set selector knob to proper number in accordance with the dataplate located on the body on the QA module. Place

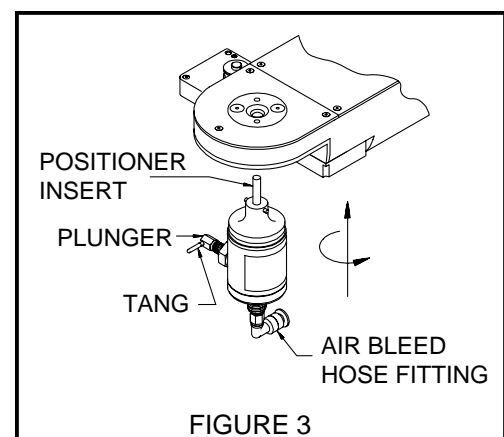
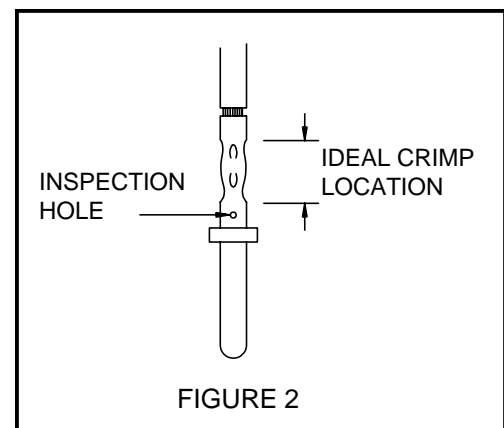
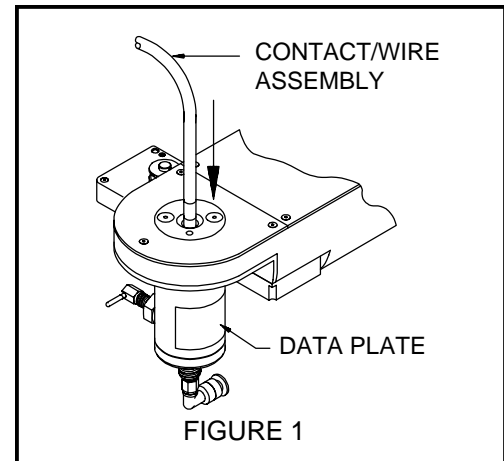

AP MODULE FOR PNEUMATIC CRIMP TOOLS

uncrimped contact with proper size wire into positioner insert and push down on contact/wire assembly until the crimp tool activates.

GAGING

To gage tool indenters, raise and rotate selector knob until number for position to be gaged is in line with the selector number arrow. Using a piece of insulated wire, push the positioner insert down and lock it in place by pulling the plunger out and rotating the tang to the deep slot. Push

Gaging limits for WA22(SS) Gaging limits for WA22P(SS) Gaging limits for WA27F(SS)

SELECTOR NUMBER	A ± .0001 GO DIA.	B ± .0001 NO-GO DIA.
1	.0130	.0180
2	.0160	.0210
3	.0190	.0240
4	.0220	.0270
5	.0260	.0310
6	.0300	.0350
7	.0340	.0390
8	.0390	.0440

SELECTOR NUMBER	A ± .0001 GO DIA.	B ± .0001 NO-GO DIA.
1	.0160	.0210
2	.0190	.0240
3	.0220	.0270
4	.0250	.0300
5	.0290	.0340
6	.0330	.0380
7	.0370	.0420
8	.0410	.0460

SELECTOR NUMBER	A ± .0001 GO DIA.	B ± .0001 NO-GO DIA.
1	.0280	.0330
2	.0320	.0370
3	.0360	.0410
4	.0390	.0440
5	.0450	.0500
6	.0520	.0570
7	.0590	.0640
8	.0680	.0730

insert down with sufficient force that tang will fully seat in slot. Push in the gaging button on the side of the special module and hold while gaging (refer to the gaging charts shown in this section). After gaging, pull plunger out and rotate tang to the shallow slot for operation.

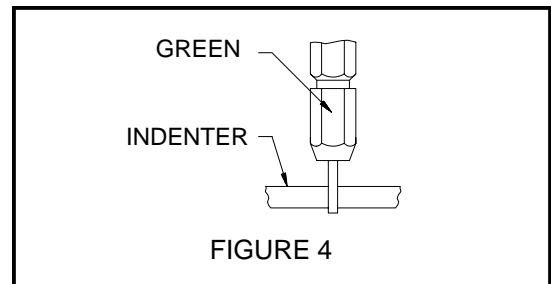

GAGING INSTRUCTIONS

"Go" Gaging

Operate tool to fully closed position, as outlined above. Insert "Go" gage end as shown. Gage must pass freely between indenter tips. See figure 4.

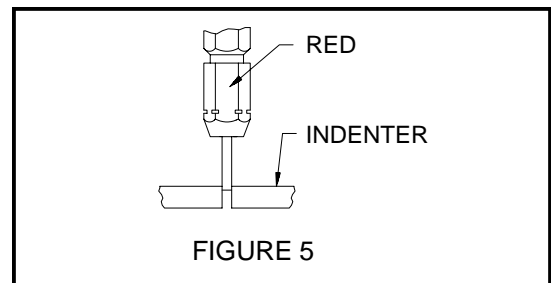

"No-Go" Gaging

Operate tool to fully closed position, as outlined above. Insert "No-Go" gage end as shown. The "No-Go" gage

Recommended Gage see fig. 6

TOOL PART NO.	GAGE PART NO.	A GO DIA.	B NO-GO DIA.	SEL NO.
WA22(SS)	G125	.0390	.0440	8
WA22P(SS)	G145	.0410	.0460	8
WA27F(SS)	G125	.0390	.0440	4

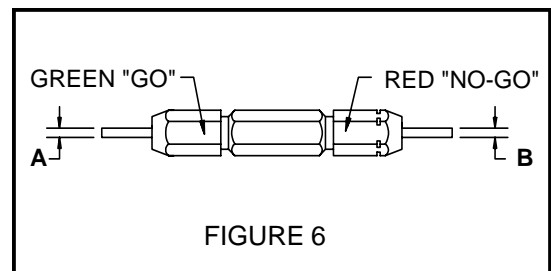

AP MODULE FOR PNEUMATIC CRIMP TOOLS

may partially enter the indenter opening, but must not pass completely through the opening. See figure 5

CAUTION! Do not crimp the gage.

TROUBLE SHOOTING

1. Tool jammed on contact/wire assembly

- A. Cause: Cycle control interrupted due to improper tool activation. Contact/wire assembly must be pushed with one swift positive motion until it bottoms out for complete cycle control of the crimp tool.

- Solution:
1. Push down on the contact/wire assembly and push in on the gaging button on the side of the special module.
 2. Raise and rotate the selector knob to the largest number possible, repeat step 1 above, (reset knob after tool releases.)
 3. Adjust shop air supply to 120 psi. (8.27 BAR), repeat step 2 above. (If tool remains jammed, see "cause B" below)

- B. Cause: Unknown.

Solution: Contact factory for further information.

CARE OF TOOL

There is virtually no maintenance required. However it is good practice to keep indenter tips free of residual color band deposits and other debris. A small wire brush may be used for this purpose.

We strongly recommend that you:

1. DO NOT immerse tools in cleaning solution.
2. DO NOT spray oil into tool to lubricate.
3. DO NOT attempt to disassemble tool or make repairs.

This is a precision tool and should be handled as such.

DMC offers complete refurbishing and recalibration service.

DMC engineers and manufactures complete tool kits to satisfy individual customer requirements, such as total aircraft support, general shop maintenance or production, on board ship and vehicle service, etc.

LIMITATION OF LIABILITY / LIMITED WARRANTY*

DANIELS MANUFACTURING CORPORATION IS NOT LIABLE FOR CONSEQUENTIAL OR SPECIAL DAMAGES OF ANY NATURE OR KIND RESULTING FROM THE USE OF ANY OF ITS PRODUCTS. OWNERS AND USERS OF DMC PRODUCTS ASSUME FULL RESPONSIBILITY FOR INSTRUCTING THEIR EMPLOYEES IN THE PROPER AND SAFE USE OF SUCH PRODUCTS.

Daniels Manufacturing Corporation warrants each new unit sold by it to be free from defects in material and workmanship under normal use and service. Its obligation under this warranty is limited to the free correction or, at its option, the refund of the purchase price of any such unit which proves defective within ninety (90) days after delivery to the first user, provided that the unit is returned with all transportation charges prepaid, and which shall appear to its satisfaction, upon inspection by it, to have been defective in material or workmanship. This warranty shall not cover any damage to such products, which in the opinion of Daniels Manufacturing Corporation, was caused by normal wear, misuse, improper operation or accident. This warranty is in lieu of all other warranties express or implied. No warranty, express or implied, is made or authorized to be made or assumed with respect to products of Daniels Manufacturing Corporation, other than that herein set forth.

*as defined by PL93-637