

# HH80C HYDRAULIC CRIMP TOOL

**DMC** DANIELS  
MANUFACTURING  
CORPORATION  
DATASHEET

SEE PAGE 8 FOR IMPORTANT INFORMATION CONCERNING LIMITED  
WARRANTY, AND LIMITATION OF LIABILITY

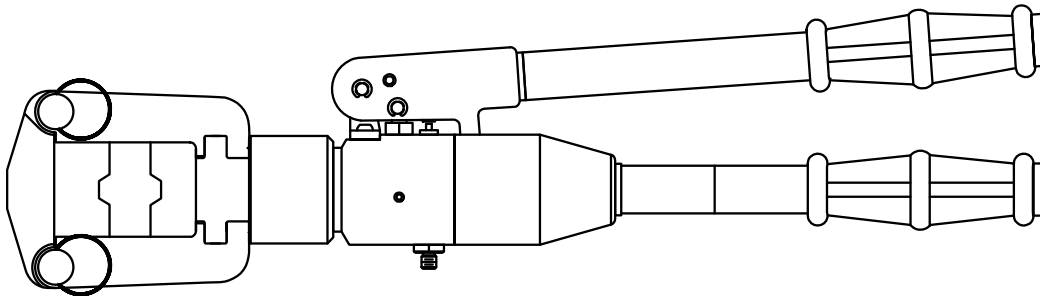

## INTRODUCTION:

The HH80C is a hand actuated hydraulic crimp tool designed to use interchangeable MS23002-XX dies (for insulated lugs) and MS90485-XX dies (for un-insulated lugs). It has a two-stage hydraulic system with an automatic relief valve to prevent over-compression.

## SPECIFICATIONS:

Force: 7 tons

Weight: 13 pounds

Length: 24 inches

DANIELS MANUFACTURING CORP. 526 THORPE ROAD, ORLANDO, FL 32824, USA  
PHONE (407) 855-6161 • FAX (407) 855-6884 • WWW.DMCTOOLS.COM • E-MAIL: DMC@DMCTOOLS.COM

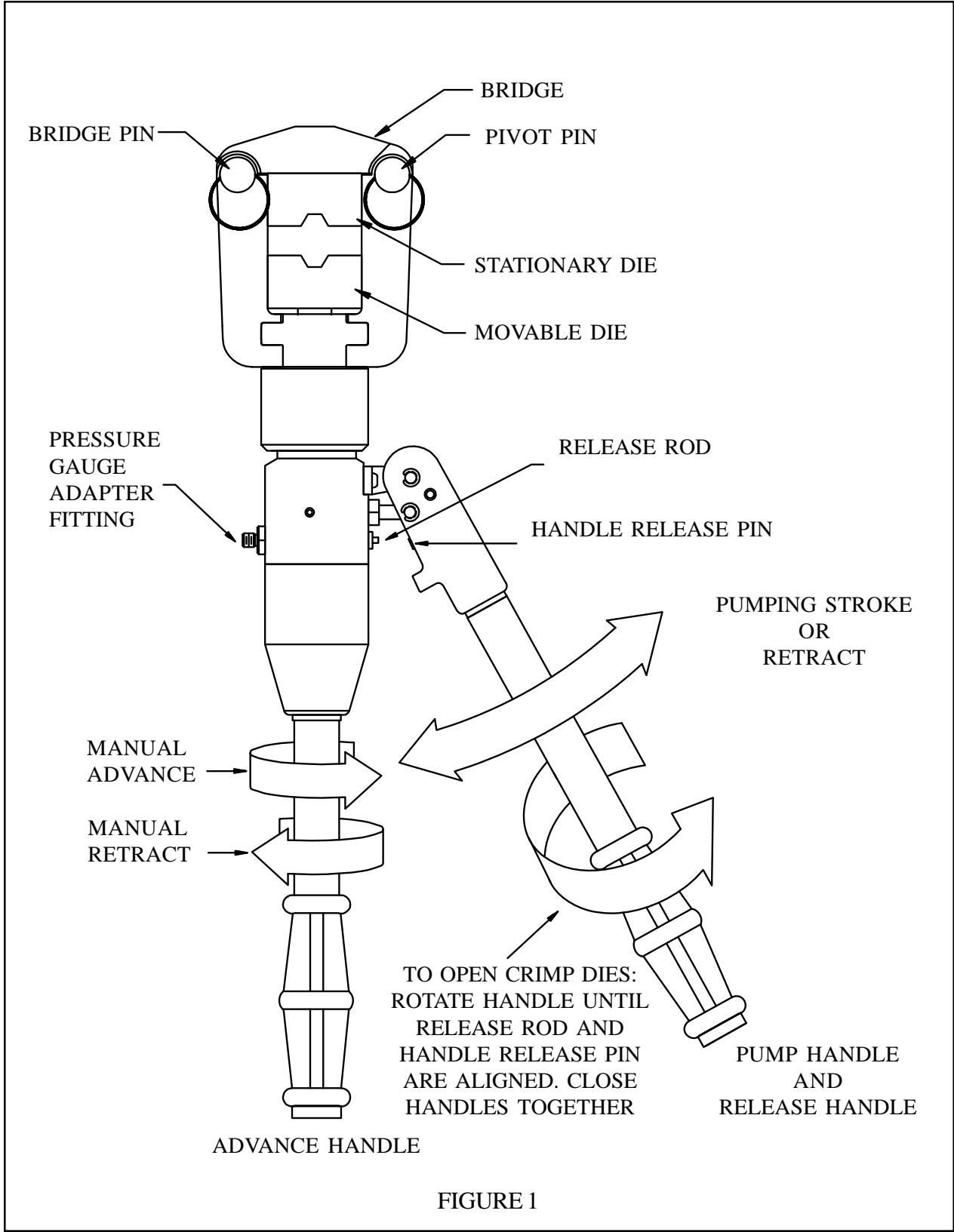

**WARNING: The fiberglass handles and neoprene grips are not designed to protect the operator in "HOT" line work.**

**COLD WEATHER NOTE:**

This tool is supplied with Drydene Paradene 32AW hydraulic oil. For operation below 20°F (-6.7°C), refill reservoir with Drydene 22AW Hydraulic oil or equivalent. In cold weather and after periods of non use, O-ring seal sticking may cause non-pumping. Rotate the advance handle clockwise to advance the dies and free any sticking O-rings.

**STORAGE:**

When tool is to be stored for any extended period of time, the tool should be pumped up approximately every three weeks to keep O-rings and seals lubricated. The tool should also be stored with the dies in the fully open position.

**GENERAL MAINTENANCE**

The HH80C tool is a hydraulically actuated mechanism which requires well trained, experienced personnel having a clean work area equipped with adequate tools for major repairs, adjustments or maintenance.

**1. KEEP THE TOOL CLEAN:**

Dirt and grit are the worst enemies of hydraulic equipment. Do not lay the tool on the ground. Wipe the entire tool thoroughly with a clean dry or slightly oily cloth after each day's use.

**2. DO NOT MAKE ADJUSTMENT TO THE TOOL:**

There are no adjustments on this tool that can be made in the field. If a tool becomes inoperative and the instructions in this manual do not help identify the malfunction, contact Daniels Manufacturing Corp. or one of its authorized distributors.

**3. CAUTION:**

**DO NOT OPERATE THIS TOOL WITHOUT A DIE SET INSTALLED! Damage to the tool can result.**

**4. STORE THE TOOL PROPERLY:**

Before storing tools for any length of time, back the rapid advance handle to the fully open position and depress the pump release handle to fully retract the crimping die. This protects the operating ram from moisture condensation and will help assure correct operation at the next period of use.

**OPERATING INSTRUCTIONS**

**INSTALLING A DIE:**

1. Pull both pivot and bridge pins to remove bridge as shown in Figure 1.
2. Place the movable die half between the die rails. Carefully lower the die and mate the die snap retainer to the snap retainer located in the ram as shown in Figure 2.
3. Place the stationary die half between the rails and lower it so the flat spring fits into the spring recess of the die rails.
4. Replace the bridge onto the die rails and snap the stationary die into the mating snap located in the bridge.

- Replace both bridge and pivot pins. (**CAUTION: THE STATIONARY DIE SNAP AND BRIDGE SNAP RETAINERS MUST BE FULLY ENGAGED BEFORE THE PINS CAN BE INSTALLED.**)

**CAUTION: Do not operate this tool without a die set installed! Damage to the tool can result.**

### CONDUCTOR PREPARATION:

Using a proper insulation stripping tool, strip the insulation from the conductor, being careful not to nick the wire strands. Thoroughly clean the conductor by wire brushing until a bright and shiny surface is obtained. All oxides and foreign matter must be removed.

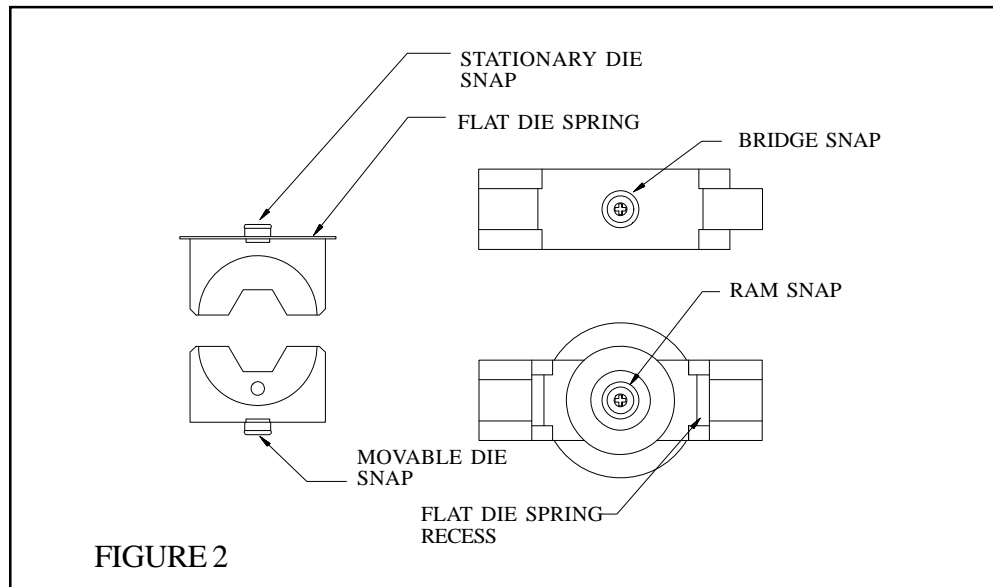

**NOTE:** Do not wire brush tin plated copper conductors or tinned connectors.

### CRIMPING A TERMINAL LUG:

- Place a lug in the movable die making sure the lug is positioned as shown in Figure 3. Rotate the advance handle clockwise until the die loosely clamps the lug (see Figure 1).
- Insert the conductor into the lug's socket making sure that the conductor is pushed fully into the lugs crimping area.
- Actuate the pump handle and the movable die will start compressing the lug. A positive trip will occur when the crimp is completed. Stop pumping. Back off the rapid advance handle (rotate counterclockwise) approximately two to three turns depending on the size of the lug.
- Release the movable die from the compressed lug by partially raising the pump handle. Then rotate the handle fully clockwise and push inward (see Figure 1). The movable die will open sufficiently to allow the lug to be removed.

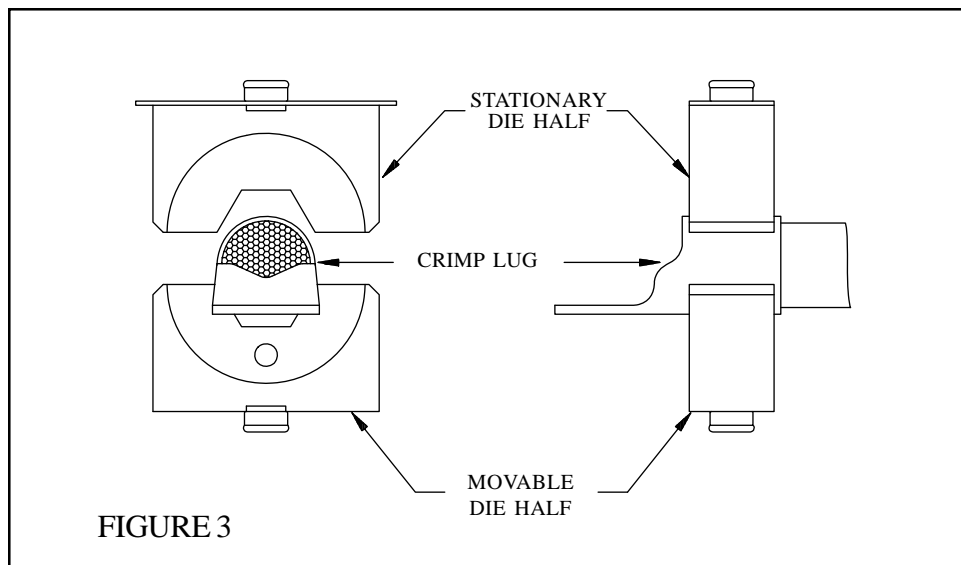

FIGURE 3

DIE SETS FOR INSULATED LUGS			
DIE P/N	LUG SIZE (AWG)	MIL. GAGE P/N	DMC GAGE P/N
MS23002-01	1/0	MS23006-01	G727
MS23002-02	2/0	MS23006-02	G728
MS23002-03	3/0	MS23006-03	G282
MS23002-04	4/0	MS23006-04	G729
MS23002-1	1	MS23006-1	G726
MS23002-2	2	MS23003-2	G281
MS23002-4	4	MS23003-4	G725
MS23002-6	6	MS23003-6	G724
MS23002-8	8	MS23003-8	G723

DIE SETS FOR UN-INSULATED LUGS			
DIE P/N	LUG SIZE (AWG)	MIL. GAGE P/N	DMC GAGE P/N
MS90485-01	1/0	MS90486-01	G835
MS90485-02	2/0	MS90486-02	G836
MS90485-03	3/0	MS90486-03	G837
MS90485-04	4/0	MS90486-04	G838
MS90485-1	1	MS90486-1	G834
MS90485-2	2	MS90486-2	G833
MS90485-4	4	MS90486-4	G722
MS90485-6	6	MS90486-6	G721
MS90485-8	8	MS90486-8	G720

**GAGING:**

The gaging of the MS23002-XX and the MS90485-XX dies is accomplished by installing the die set into the tool as described on page 3. Rotate the advance handle clockwise until the die set is completely closed. **DO NOT OVERCOMPRESS THE DIE SET DURING THE GAGING OPERATION!** The dies must be flush against each other with light force only.

### "GO" GAGING

Insert the "GO" gage end as shown. The gage must pass freely through the cavity in the die set.

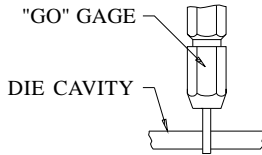

### "NO-GO" GAGING

Try to insert the "NO-GO" gage end as shown. The gage may partially enter the cavity but must not pass completely through the opening.

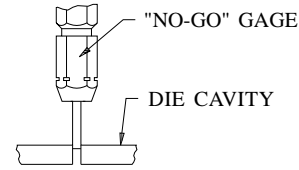

### **CHECKING PUMP OIL LEVEL:**

Check reservoir oil level of tool by screwing inward on the advance handle. Oil supply is adequate if the dies touch before the advance handle is completely advanced. Add oil if required (see ADDITION OF HYDRAULIC OIL).

### **LOSS OF HYDRAULIC OIL:**

Hydraulically actuated tools will gradually lose their hydraulic oil over a period of time. This loss is caused by the adherence of small amounts of oil to the moving parts exposed to the outside, such as plungers, pistons, and rams, and from occasional leakage around mechanical seals. **A small loss of hydraulic oil is normal and will not affect the operation of the HH80C tool.** However, if the level drops too low, air can become trapped in the hydraulic system causing the tool to develop a "spongy" feel, preventing it from operating. Occasional hydraulic oil checks can be performed as follows:

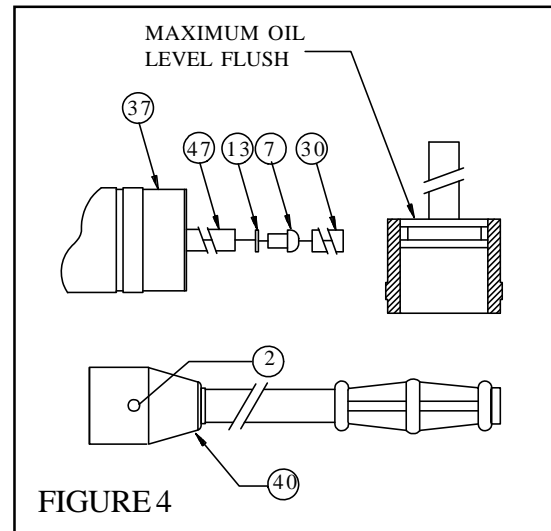

### **ADDITION OF HYDRAULIC OIL:**

For cold weather regions, an oil with a viscosity @ 100° F, SUS114 should be used. Caution should be exercised to assure that oil of different types are not mixed when tool reservoirs are replenished.

### **DO NOT USE BRAKE FLUID!**

1. Rotate the advance handle fully counterclockwise to retract the movable die and return the oil to the oil chamber.
2. Actuate the pump release handle and confirm that the die is in the fully open position (see Figure 1).
3. Hold the tool with the crimping head down on a clean surface and remove set screw 2 (see Figure 4), and unscrew cover (Item 40) along with the handle assembly.
4. Remove plunger spring (Item 30) and loosen oil fill screw (Item 7). Do not remove Item 7 at this time.
5. Grasp the stem of plunger (Item 47) and lift it so the plunger is no higher than the oil reservoir section of the body (Item 37) (see Figure 4).

6. Remove filler screw (Item 7), O-ring (Item 13) will also be removed with the filler screw.
7. Fill the reservoir with the proper hydraulic oil (see COLD WEATHER NOTE for choice of oils).
8. Apply slight pressure to the plunger to allow the oil to just reach the surface of the fill hole and replace the filler screw (Item 7) and O-ring (Item 13).
9. Reassemble the tool by reversing the order of operations described above (steps 5 through 3).

**CAUTION:** *USE HYDRAULIC OIL AS SHOWN BELOW OR ONE THAT MEETS THE SPECIFICATIONS LISTED BELOW.  
DO NOT USE BRAKE FLUID!*

**Hydraulic oil:** Drydene Paradene

Tool supplied with Drydene Paradene 32AW hydraulic oil.

Below 20° F (-6.7° C), use Drydene 22AW hydraulic oil (or equivalent).

**Manufactured by:**

Drydene Oil Company

9300 Pulaski Highway

Baltimore, MD 21220 (USA)

*For service and support of this tool, contact Daniels Manufacturing Corp. at:  
Phone: (407) 855-6161 Fax: (407) 855-6884 E-mail: dmc@dmctools.com*

*Daniels Manufacturing Corp. offers complete refurbishing and recalibration services.*

*DMC specially engineers and manufactures complete tool kits to satisfy individual customer requirements, such as total aircraft support, general shop maintenance or production, on board ship and vehicle service, etc.*

## **INVALIDATION OF LIMITED WARRANTY**

This manual is provided to those owners of Daniels Manufacturing Corporation (DMC) products who have elected to conduct in-house repairs of such products and who thereby consent to waive any rights which they otherwise might have had under the DMC limited warranty applicable to such products.

DMC provides complete repair and maintenance service for all of its products. Owners of DMC products are warned that any tampering, including partial or complete disassembly of the product or attempted repairs of the product will invalidate the limited warranty applicable to said product.

## **LIMITATION OF LIABILITY**

Daniels Manufacturing Corporation (DMC) is not liable for consequential or special damages of any nature or kind resulting from the use, or misuse, of any of its products. Owners and users of (DMC) products assume full responsibility for instructing their employees in the proper and safe use of such products.

## **LIMITED WARRANTY**

Daniels Manufacturing Corporation (DMC) warrants each new product sold by it to be free from defects in material and workmanship under normal use and service. DMC's obligation under this warranty is limited to the free correction or, at DMC's option, the refund of the purchase price of any such product which proves defective in normal service within ninety (90) days after delivery to the first user, provided that the product is returned to DMC with all transportation charges prepaid in which shall appear to DMC's satisfaction, after DMC's inspection, to have been defective in material or workmanship, it being understood that DMC products are not consumer products. This warranty shall not cover any damage to any product which, in the opinion of DMC, was caused by normal wear, misuse, improper operation, tampering, neglect or accident. This warranty is in lieu of all other warranties express or implied. No warranty, express or implied, is made or authorized to be made or assumed with respect to products of Daniels Manufacturing Corporation other than those herein set forth.